

THIS DRAWING IS UNPUBLISHED. RELEASED FOR PUBLICATION, 19 .
 © COPYRIGHT 19 BY AMP INCORPORATED. ALL INTERNATIONAL RIGHTS RESERVED.

LOC	DIST	P	F	REVISIONS				
				ZONE	LTR	DESCRIPTION	DATE	APPD
AF	50				N	REDRAW & ADD -1 PER 0710-0310-95	06/JUL/95	PF/GY

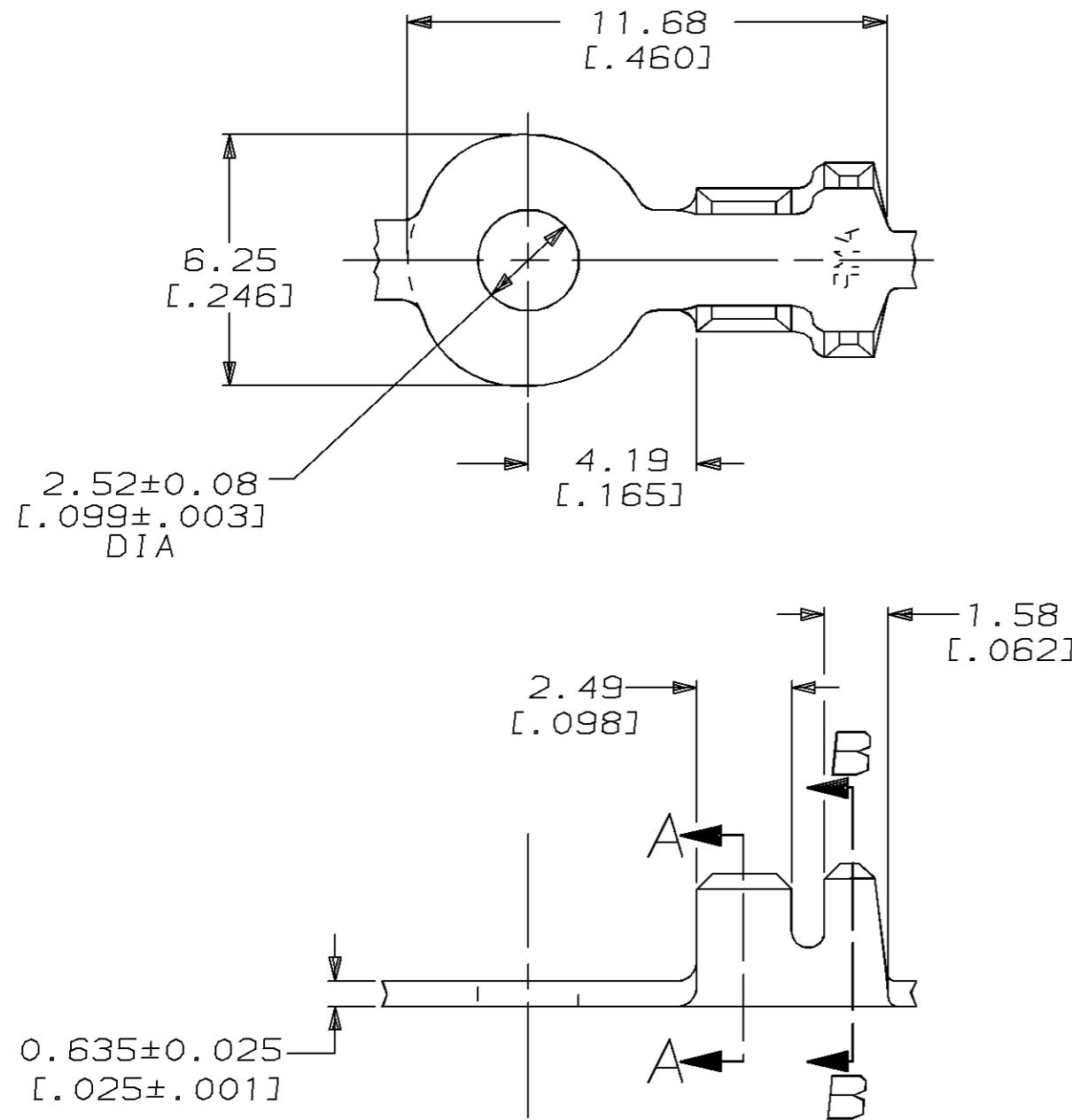

- 1 CONTINUOUS STRIP ON REEL.
- 2 FINISH-0.002032 [0.000080] MIN TIN PLATE PER MIL-T-10727.

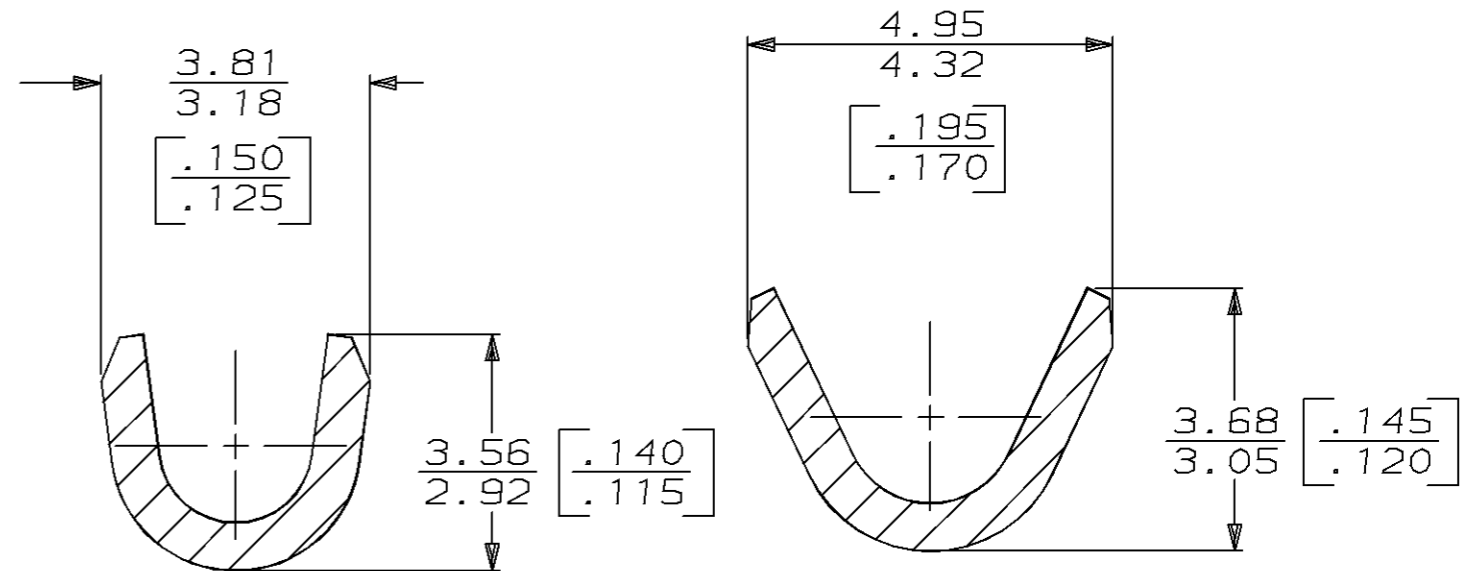

SECTION A-A
SCALE 10:1

SECTION B-B
SCALE 10:1

0.635±0.025 [0.025±.001]

THIS DRAWING IS A CONTROLLED DOCUMENT FOR AMP INCORPORATED. IT IS SUBJECT TO CHANGE AND THE CONTROLLING ENGINEERING ORGANIZATION SHOULD BE CONTACTED FOR THE LATEST REVISION.

	$\triangle 2$	1.90-2.79 DIA [0.075-.110]	[20-16] AWG	41406-1	
	FINISH	INSULATION RANGE	WIRE RANGE	PART NO	
DO NOT SCALE PRINT. UNLESS SPECIFIED DIMENSIONS IN mm [INCHES] TOLERANCES ON: 2 PLC DEC ± 0.38 [0.015] 3 PLC DEC ± - ANGLES ± -	MATERIAL	DR 06/JUL/95 PHILLIP M FORTNEY	AMP AMP Incorporated Harrisburg, PA 17105-3608		
	082 BRASS	CHK 06/JUL/95 MICHAEL S FEHER			
	FINISH	APPD 06/JUL/95 GARY YETTER	NAME RING		
	SEE TABLE	APPD 06/JUL/95 MARK BARNABA			
		PRODUCT SPEC	SIZE	CAGE CODE	DRAWING NO
		APPLICATION SPEC	B	00779	C -41406
		WEIGHT -	SCALE	6:1	SHEET 1 OF 1

CUSTOMER DRAWING